

XP95

ZONE MONITOR

FUNCTION

The XP95 Zone Monitor powers and controls the operation of a zone of up to 20 Apollo Series 60 or Series 65 fire detectors from a loop of XP95 addressable detectors and ancillary devices.

FEATURES

The Zone Monitor is factory preset to return a value of 16 when all detectors on the zone are in quiescent state and 64 when a detector changes to the alarm state. The Zone Monitor latches in the alarm state.

A 6.2k Ω end-of-line resistor is fitted to monitor cables for open- and short-circuit faults. Alternatively, an active end-of-line monitor may be used in conjunction with diode bases and a capacitor of up to 50 μ F fitted at the Zone Monitor wiring terminals.

In either case a value of 4 is transmitted during open- or short-circuit faults.

ELECTRICAL CONSIDERATIONS

The Zone Monitor is loop powered and operates at 17–28V DC with protocol pulses of 5–9V.

PROTOCOL COMPATIBILITY

The Zone Monitor operates only with control equipment using the Apollo Series 90, XP95 or Discovery protocol.



Part no 55000-813

PROTOCOL BIT USAGE

The control equipment transmits a 10-bit message to the Zone Monitor:

The **output (or forward command) bits** from the control equipment have the following functions:

When **output bit 2** is set to logic 1 on two or more consecutive polling cycles, the current limit on the zone is increased to enable full illumination of the LED of the detector in the alarm state.

When **output bit 1** is set to logic 1 on two or more consecutive polling cycles, the remote test facility is initiated and a load equivalent to a fire alarm state is placed across the wiring to the conventional detectors.



© Apollo Fire Detectors Limited 2000-2005



INVESTOR IN PEOPLE



Assessed to ISO 9001: 2000
Quality Systems Certificate number 010



36 Brookside Road, Havant, Hampshire PO9 1JR, England.

Tel: +44 (0)23 9249 2412 Fax: +44 (0)23 9249 2754 Website: www.apollo-fire.co.uk Email: sales@apollo-fire.co.uk

When **output bit 0** is set to logic 1 on two or more consecutive polling cycles, voltage on the zone is switched to 0V to reset the detectors.

When **output bit 0** is set to logic 0 on two or more consecutive polling cycles, the zone voltage is restored.

The zone voltage low period should be at least 2 seconds.

The next **seven bits** transmitted correspond to the **address (as set on the DIL switch)** of the device to be polled.

A response message is then sent by the Zone Monitor to the control equipment:

The **interrupt bit** is always set to logic 0.

The seven **analogue value bits** return a value of 16 in normal conditions. A value of 64 is sent if a detector changes to alarm state. If an open- or short-circuit fault occurs, or a reset is in progress, the Zone Monitor returns a value of 4.

The **input bits** confirm execution of the commands given in the output bits as follows:

Input bit 2 is set to logic 1 when the Zone Monitor has accepted a command to increase the current limit on the zone to fully illuminate a detector LED.

Input bit 1 is set to logic 1 when the Zone Monitor has accepted a command to apply a remote test.

Input bit 0 is set to logic 1 when the Zone Monitor has accepted a command to reset the zone (zone voltage low).

The Zone Monitor sends **seven bits** of data to confirm its address and then **one bit (XP95 flag)** to confirm that the device can use the XP95 protocol.

The **alarm flag** is set if another device is in the alarm state and is not itself being interrogated. The Zone Monitor places an alarm flag every 32 polling cycles if its analogue value is 64.

The next **five bits** are the second analogue block and are not used by the Zone Monitor.

The **parity bit** is set to logic 1 or logic 0 so that the Zone Monitor always responds with an even number of data bits.

The final **seven bits** are used to transmit the alarm address if the alarm flag is set.

NOTES ON USE

1. *Zone voltage is regulated to $19 + 1V$ for any loop voltage greater than 22V. If the loop voltage falls below 22V, the zone voltage is approximately 1.5V below the loop voltage. It is important to ensure that under worst-case conditions, the zone voltage is above the minimum operating voltage for the conventional detectors.*
2. *Alarm conditions are latched internally by the Zone Monitor. It is therefore necessary to reset the alarm even if non-latching conventional detectors are used.*
3. *The Zone Monitor may be used to power and control intrinsically safe detectors via safety barriers with resistance values between 300 and 350 ohms. To use the Zone Monitor with intrinsically safe devices, cut the wire link near the LED.*
3. *To comply with BS5839: Part 1 response time requirements, manual call points can only be incorporated into zones connected by the Zone Monitor to XP95 systems if the control panel is programmed to recognise the alarm flag.*
4. *Manual call points can be located at any point in the zone wiring if active end-of-line monitoring with diode detector bases is used. If a 6.2 kW resistor is used for monitoring, manual call points must be connected between the Zone Monitor and the first detector (see Figure 2).*

MECHANICAL CONSTRUCTION

The Zone Monitor is normally supplied with a backbox for surface mounting, and is also available without the backbox for flush mounting. Both versions are for indoor use only.

A red LED, visible through the front cover of the enclosure, is lit when the zone is in an alarm state.

The backbox is a polycarbonate moulding.

Dimensions and weight of Zone Monitor (surface mount):

150mm x 90mm x 48mm 230g.

Technical Data

Series 90/XP95 line voltage	17V–28VDC
Zone voltage	
(Loop voltage > 22V)	19V +1V
(Loop voltage < 22V)	loop voltage –1.5V
Maximum current consumption at 24V (6.2 EOL)	
switch-on surge, max 150ms	2.8mA
quiescent	4mA+detector load
alarm	11mA
(19mA when increased current enabled)	
short-circuit	11mA
End-of-line resistor value	6.2kΩ + 5% 1/3 W
Stabilisation time on power-up	4 seconds
Maximum capacitor on zone terminals	50μF
Operating temperature	–20° C to +70° C
Humidity (no condensation)	0% – 95%
Shock, Vibration and Impact	EFGS/F/95/007
IP rating	54
Radiated emissions	to BS EN 50081–1
Radiated immunity	to BS EN 50081–2
CE marked	

EMC DIRECTIVE 89/336/EEC

The XP95 Zone Monitor, Part No. 55000-813/814 complies with the essential requirements of the EMC directive 89/336/EEC, provided that it is used as described in this PIN sheet.

A copy of the Declaration of Conformity is available from Apollo on request.

Conformity of the XP95 Zone Monitor with the EMC directive does not confer compliance with the directive on any apparatus or systems connected to

Schematic diagram and wiring connections

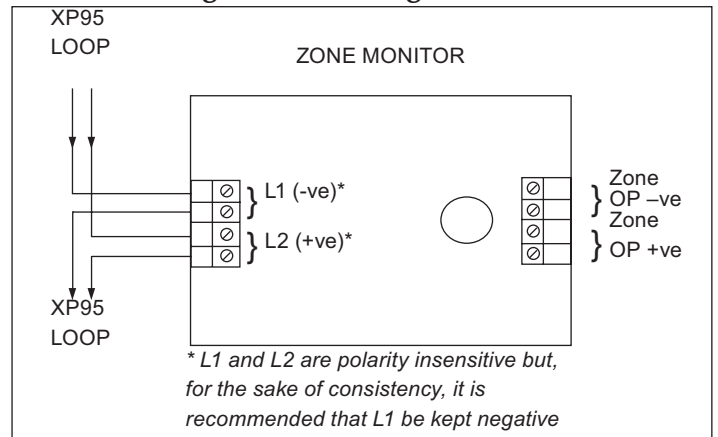

Fig.1 Connection to loop

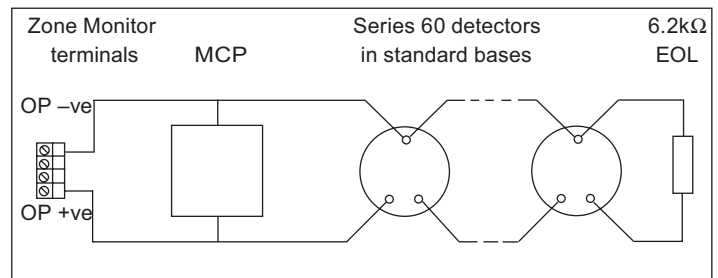

Fig.2 Zone connection - standard bases with 6.2kΩ monitoring resistor at end-of-line

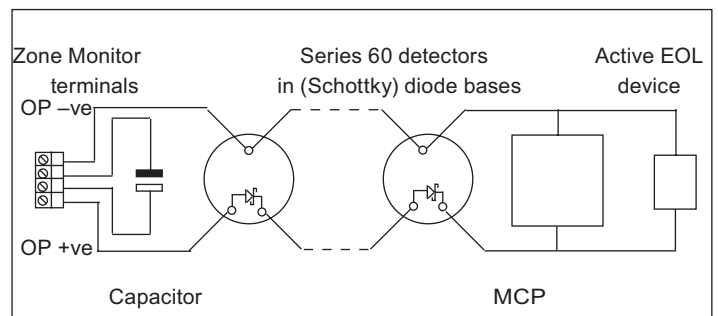

Fig.3 Zone connection – diode bases with active EOL device

Table of analogue values related to circuit status and zone load (input resistance)

Safe area circuit	Intrinsically safe circuit	Status	Analogue value
<150Ω	<450Ω	Short-circuit fault	4
50Ω to 200Ω	450Ω to 500Ω	Indeterminate	4 or 64
200Ω to 2.6kΩ	500Ω to 2.6kΩ	Alarm	64
2.6kΩ to 3.5kΩ	2.6kΩ to 3.5kΩ	Indeterminate	64 or 16
3.5kΩ to 6.8kΩ	3.5kΩ to 6.8kΩ	Normal	16
6.8kΩ to 7.5kΩ	6.8kΩ to 7.5kΩ	Indeterminate	4 or 16
>7.5kΩ	>7.5kΩ	Open-circuit fault	4