



Series 65 Base Mounted UV Flame Detector Installation Guide

General

The Series 65 (S65) Ultraviolet (UV) Flame Detector, part no 55000-025, is designed for use where open flaming fires may be expected. It is sensitive to ultraviolet radiation emitted by flames during combustion. Since it requires only UV radiation the S65 Flame Detector responds also to stationary flames with no flicker such as cigarette lighters and blue gas flames.

Response to flames

The UV Flame Detector signals an alarm state by switching an alarm latch on, increasing the current drawn from the supply from 550 μ A to a maximum of about 75mA. This fall in the impedance of the detector is recognised by the control panel as an alarm signal.

The alarm current also illuminates the detectors integral LED. A remote indicator connected between the L1 IN terminal and the -R terminal will have a voltage equal to the supply voltage less 1 volt across it and so will illuminate.

Electrical considerations

To ensure correct operation of the detector the control panel must be arranged to supply a maximum of 33V DC and a minimum of 12V DC in normal operation. The supply may fall to 6V DC in alarm conditions if a supply current of at least 10mA is available at this voltage.

To ensure effective illumination of the integral LEDs and any remote indicator, the supply to the detector should exceed 12V. To restore the detector to quiescent condition, it is necessary to extinguish any flames in view and interrupt the electrical supply to the detector for a minimum of one second.

Sensor window contamination

It is important to keep the sensor window clean and checks should be carried out at regular intervals—determined locally according to the type and degree of contamination encountered— to ensure optimal performance of the flame detector.

It is recommended that the flame detector be disabled when the window is being cleaned.

Applications for UV flame detectors

Flame detectors are used when detection is required to be unaffected by convection currents, draughts or wind; tolerant of fumes, vapours, responsive to a flame up to 25m away and fast reacting.

Typical applications examples are:

- engine room
- factory
- garage
- hospital
- printing
- warehouse

Applications and locations to avoid:

- outdoors
- open windows and doorways
- electric sparks, arcs and welding
- UV lamps
- radiation sources
- prolonged ambient temperatures above 60°C
- exposure to water and ice
- gathering of dust or oil films on sensor window
- flood or spot lighting falling directly on UV optics
- obstructions to field of view

Technical Data

Supply voltage	12–33V DC (polarity insensitive)
Quiescent current	550µA
Alarm voltage	6 to 33V
Normal alarm current	61mA at 28V 54mA at 24V 20mA at 10V
Remote output characteristics	Remote is a current sink to the negative line limited to 17mA
Alarm indicator	Red, Light Emitting Diode (LED)
Design alarm load	420Ω in series with a 2V drop
Hold voltage	6V (min)
Holding current	10mA (min)
Minimum voltage required to illuminate indicators	12V
Alarm reset voltage	1V
Alarm reset time	1 second
Operating Range	25m for 0.1m ² n-heptane fire, EN54-10, class 1 2m for 0.1m ² n-heptane fire, EN54-10, class 3
Sensitivity Switch Options	class 1 (default) and class 3, as in EN54-10, clause 5.5
Field of view	90° cone
Spectral response	UV 185 to 260nm
Operating temperature	–40°C to +70°C (no condensation or icing)
Storage temperature	–40°C to +85°C
Relative humidity	0-95% (no condensation)
IP rating	66
Housing material	White polycarbonate V-0 rated to UL94
Dimensions	100mm diameter 40mm height, 48mm in base
Weight	150g detector, 210g in base

Additional Equipment

Stainless steel adjustable mount with deck head box	Part no. 29600-458
Portable flame detector test unit	Part no. 29600-226
Deckhead Mounting Box	Part no. 45681-217

Functional Testing

Testing the operation of the detector can be achieved in two ways, provided it is safe to do so:

- A real flame from a portable flickering yellow bunsen flame or cigarette lighter
- A portable flame detector tester unit

Maintenance Guide

The flame detector is designed to give years of trouble-free operation with minimal attention. However the periodic maintenance steps listed below are essential to maintain reliable fire protection.

1. Inform all appropriate personnel of intention to work on the flame detector.
2. Disable any automatic systems that may be activated by the flame detector if not required as part of the maintenance check.

Alarms	Extinguishers	Control
Audio/Visual	Gas systems	Plant stops
Auto dialers	Water sprays	Dampers/doors

3. Check that the flame detector's control panel is functioning correctly and shows no faults.
4. Inspect the detector viewing window for any build-up of dust or other contaminants on the optical surface. If necessary clean the optical surface with a cotton wipe wet with commercial liquid glass cleaner, but not polishes. Rinse with clean water and dry with a clean cloth.

The detector specification for performance is with a clean optical sensor window. Contaminants like dust, oil and paint will reduce sensitivity.

5. Ensure the detector still has a clear line of sight of the area it is protecting and no obstacles obstruct its view.
6. Check that the detector is securely fitted.
7. Visually check the exterior of the detector for any mechanical or corrosive damage.
8. Test the operation of the detector with either a portable flame sensor test unit or if practical a flame.
9. Reinstate any automatic system disabled during maintenance.
10. Inform all appropriate personnel on completion of the maintenance work and if necessary record this work.

Quantities required and positioning of detectors

The number of detectors required and their positioning depends on:

- the anticipated size of the flame
- the distance of the flame from the detector and
- the angle of view of the flame detector

The flame detector is designed to operate to Class 1 performance as defined in EN54-10. The detector will, therefore, detect a flame of approximately 0.1m² or a clear flame of 0.25m² at 25m.

In fact, the flame detector will detect fires at distances of up to 40m, but the flame size at such distances needs to be proportionally greater in order to be sure of reliable detection. Thus the flame that can be detected at 25m, provided that its size is not less than 0.1m², will have to be 0.4m² in order to be detected at 40m. In a rectangular room the distance from the flame detector to the fire is calculated by the formula:

$$\sqrt{L^2 + W^2 + H^2}$$

In the example shown in Fig 1 the room in which the flame detector is to be installed measures 20m x 10m x 5m; the distance from the detector to the flame will therefore be:

$$\sqrt{20^2 + 10^2 + 5^2}$$

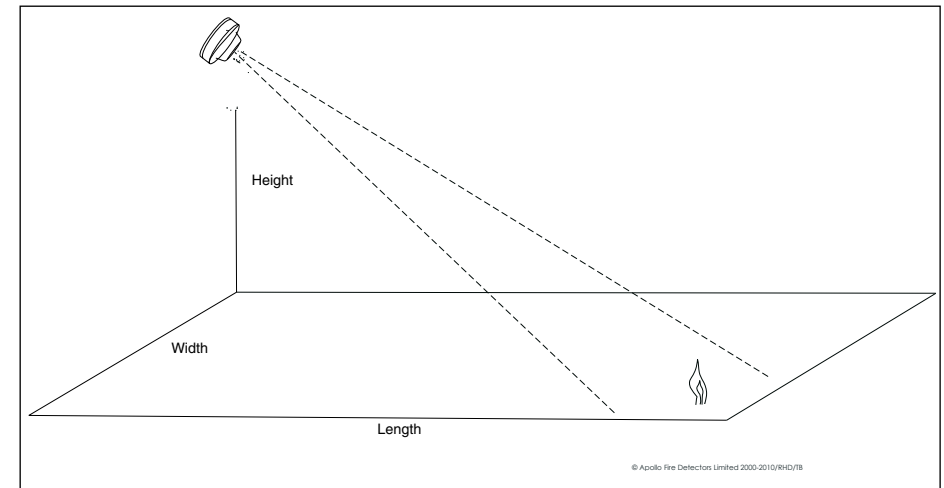

Fig 1 Calculation of distance from detector to flame

The flame detector should be positioned at the perimeter of the room, pointing directly at the area of the anticipated flame or at the centre of the area to be protected. If the detector cannot 'see' the whole of the area to be protected, one or more additional detectors may be required.

The flame detector is not affected by most normal indoor light sources but should be positioned so that daylight is not in view.

The UV Flame Detector can also be ceiling mounted, positioned above the anticipated flame source or at the centre of the area to be protected, perpendicular to the floor below. If the detector cannot see the whole of the area to be protected, one or more additional detectors may be required. Refer to the angle of view diagram Fig. 3 to establish the detector performance. The area of detection is dependent on the detectors height above the likely source of flame. The detector has a 90° conical field of view or 45° either side of the viewing axis centre line. The maximum ceiling height is 20m. If the detector is perpendicular to floor and at a height of 10m then the detector will view a circular floor area below with a 10m radius (20m diameter circle).

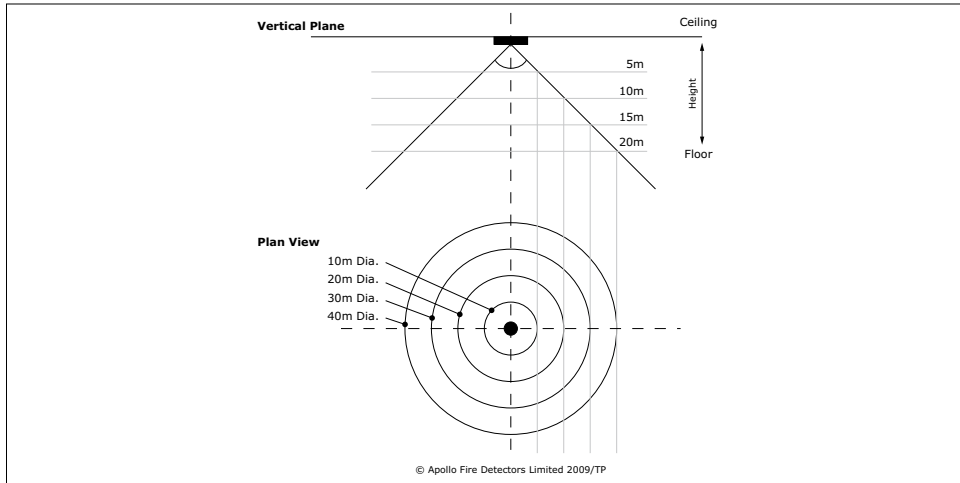

Fig 2 Ceiling mounting example

The UV flame detector has an angle of view of approximately 90°, as shown in the diagram below.

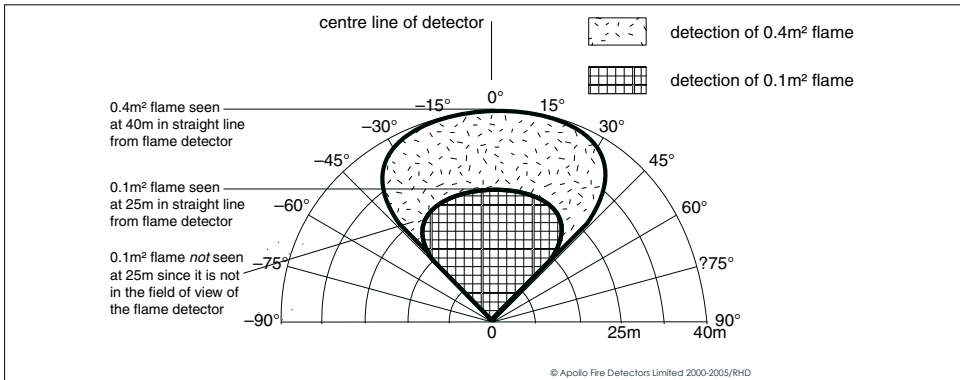

Fig 3 Angle of view of UV Flame Detector

To meet the requirements of EN54-10 clause 5.4, where the ratio of the response points $D_{max}:D_{min}$ should not exceed 1.41. The horizontal and vertical viewing angles α_{max} should not exceed $\pm 40^\circ$.

Sensitivity setting

The sensitivity switch is available and is used to set the sensitivity of the flame detector to class 1 or class 3. For most practical purposes the switch should be set to class 1 (default setting), the sensitivity required to detect flames as described in the section 'Quantities required and positioning of detectors', page 3.

In exceptional cases the flame detector may be set to class 3 operation in order to avoid nuisance alarms being caused by radiation sources that are close to the detector and can not be moved. The rotary sensitivity switch is located on the detector rear behind the label. To set to class 3, rotate the switch 90° clockwise. To return the sensitivity switch to the class 1 setting, rotate the switch 90° counter clockwise.

Installation

The flame detector is mounted on any Series 65 base and would normally be wall or ceiling mounted preferably on an adjustable bracket to adjust the angle of view.

The standard base mounting is used for horizontal viewing, eg, along corridors or along the length of industrial processes or vertical viewing inside fume cupboards or over hoppers. Flame detectors should be fitted to solid walls or rigid constructions that do not move and are not subject to vibration.

If fitting to an XP95 Zone Monitor do not fit more than one device per zone.

If fitting to a conventional control panel, please verify the quantity per zone with the chosen panel manufacturer.

Wiring

The flame detector has five connections: L1 IN, L1 OUT, L2, -Remote and functional earth/screen. The connections are accessed by removing the detector from its base. See Fig 4 for connection diagram.

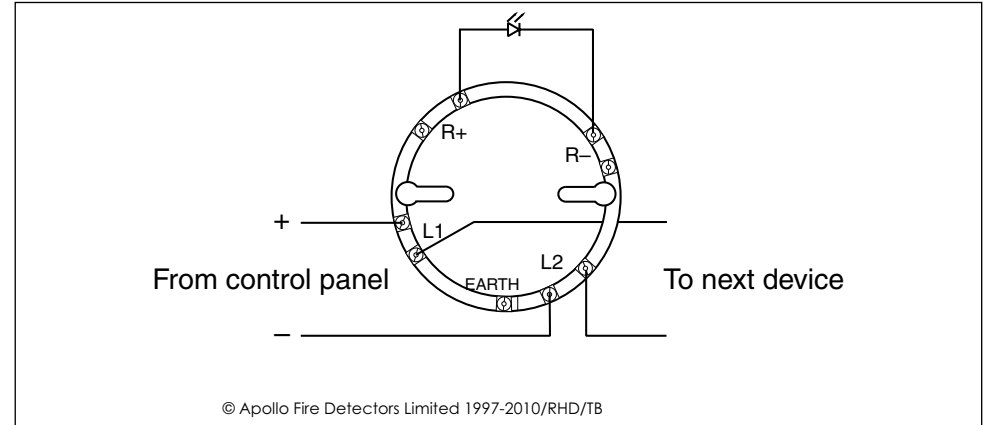

Fig 4 UV Flame Detector base connections

Terminal Descriptions

1	+L2	+Line IN and OUT
2	-L1	-Line IN and OUT
3	+R	+Remote LED
4	-R	-Remote LED
5	EARTH	Functional Earth/Screen (Isolated)