

Protocol bit use

Output Bit Settings			Sounder action
2	1	0	
0	0	0	Sounder off
0	0	1	Alarm slow whoop
0	1	0	Alert continuous
0	1	1	Alarm slow whoop
NB Output bit 2 is not used			

Input bits confirm the operation of the output bits

Troubleshooting

Before investigating individual units for faults, it is important to check the system wiring is fault free. Earth faults on data loops may cause communication errors. If an XP95 test set is used to test the sounder operation may be intermittent. To avoid this, operate the sounder and exit the single address test.

Fault Finding

Problem	Possible Cause
No response or missing	Incorrect address setting Incorrect loop wiring Too many sounders between isolators
Sounder fails to operate	Control panel has incorrect cause and effect programming



Slow Whoop Intelligent Base Sounder Installation Guide

General

This guide describes the installation of the following sounders

Part number	Comments
45681-267	Slow whoop base sounder

The sounders may be connected only to control panels which use either the XP95 or the Discovery protocol.

Note: The Intelligent Base Sounder is Type A, ie, it is not suitable for outdoor use. The Slow Whoop Intelligent Base Sounder complies with the requirements of EN54-3 : 2001 but the tone is as specified in Dutch Standard NEN2575

Mounting Instructions

The Base Sounder may be secured to a conduit box or surface mounted (providing there is access through the surface for cabling). If an XP95 base is to be attached, it will be necessary to make all electrical connections, set the address, select the desired output and master/slave configuration before securing the XP95 base to the sounder.

Wiring details

Note: The sounder is polarity sensitive (supply reversal protected) and will not function if wired incorrectly.

Connect the loop cables to the sounder terminal block, observing polarity. The wiring terminals accept solid or stranded cables up to 2.5mm².

Connect the wires from the sounder to the XP95 base terminals, red to L2 and black to L1 (**Fig 1**).

When using the sounder as a stand-alone unit, the cap (red cap part no 29600-256, white cap part no 29600-257) will need to be secured with a 1.5mm hexagonal driver (part no 29600-095).

Technical data

Operating voltage	17—28V DC
Sounder output	switch selectable 84±3 or 91±3dB(A)
SPL polar plot data is available in document M04-003, available on request.	
Current consumption at 24V DC	
quiescent	300µA
switch-on surge	1.2mA for 1 sec
sounder operated at 84dB(A)	3.5mA
sounder operated at 91dB(A)	8.25mA
IP rating	2IC

The maximum number of Intelligent Base Sounders permitted between standard XP95 isolators (part no. 55000-720) or isolating bases (part no. 45681-321/284) is 20, depending on the loop loading. *Apollo's Loop Calculator* is a program available as a free download from www.apollo-fire.co.uk and can be used to check the loading of any proposed loop design.

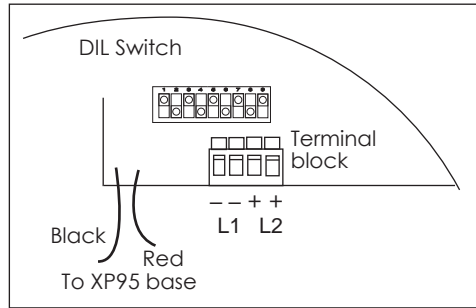

Fig 1 Connecting diagram

Address and Sound Output Setting

The address of the base sounder is set using seven segments of the nine-segment DIL switch (Fig 2). Segments 1-7 of the switch are set to "1" or "0" (ON), using a small screwdriver or similar tool. A complete list of address settings is shown below.

The eighth segment selects the sound output level, 84dB or 91dB (ON).

Master/slave setting

Sounders are factory set with the ninth segment of the DIL switch set to '0' — 'Master'. Please see PIN sheet PP2136 for an explanation of this concept. Do not set sounders as slaves without consulting this document.

DIL switch setting		DIL switch setting		DIL switch setting		DIL switch setting		DIL switch setting	
addr	1234567	addr	1234567	addr	1234567	addr	1234567	addr	1234567
1	1000000	11	1101000	21	1010100	31	1111100	41	1001010
2	0100000	12	0011000	22	0110100	32	0000010	42	0101010
3	1100000	13	1011000	23	1110100	33	1000010	43	1101010
4	0010000	14	0111000	24	0001100	34	0100010	44	0011010
5	1010000	15	1111000	25	1001100	35	1100010	45	1011010
6	0110000	16	0000100	26	0101100	36	0010010	46	0111010
7	1110000	17	1000100	27	1101100	37	1010010	47	1111010
8	0001000	18	0100100	28	0011100	38	0110010	48	0000110
9	1001000	19	1100100	29	1011100	39	1110010	49	1000110
10	0101000	20	0010100	30	0111100	40	0001010	50	0100110
51	1100110	61	1011110	71	1110001	81	1000101	91	1101101
52	0010110	62	0111110	72	0001001	82	0100101	92	0011101
53	1010110	63	1111110	73	1001001	83	1100101	93	1011101
54	0110110	64	0000001	74	0101001	84	0010101	94	0111101
55	1110110	65	1000001	75	1101001	85	1010101	95	1111101
56	0001110	66	0100001	76	0011001	86	0110101	96	0000011
57	1001110	67	1100001	77	1101001	87	1110101	97	1000011
58	0101110	68	0010001	78	0111001	88	0001101	98	0100011
59	1101110	69	1010001	79	1111001	89	1001101	99	1100011
60	0011110	70	0110001	80	0000101	90	0101101	100	0010011
101	1010011	106	0101011	111	1111011	116	0010111	121	1001111
102	0110011	107	1101011	112	0000111	117	1010111	122	0101111
103	1110011	108	0011011	113	1000111	118	0110111	123	1101111
104	0001011	109	1011011	114	0100111	119	1110111	124	0011111
105	1001011	110	0111011	115	1100111	120	0001111	125	1011111
								126	0111111

Example of address and output setting

Address shown is 78, a sound output of 84dB selected and the sounder configured as a master sounder.

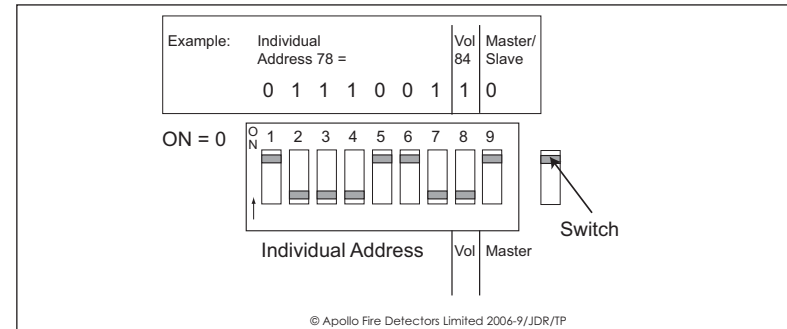

Fig 2