



# Discovery Open-Area Voice Alarm Devices

Byte Value	Attention Drawing Signal (Tone)	Message	Tone / Message Number	Attention Drawing Signal (Tone)	Message	Tone / Message Number
1	Apollo Evacuation Tone* (550Hz for 0.5s, 825Hz for 0.5s)	Attention please. Fire has been reported in the building. Please leave immediately by the nearest exit. Fire has been reported in the building. Please leave immediately by the nearest exit.	M1	Apollo Alert Tone (1s off, 825Hz for 1s)	This is a fire alert. This is a fire alert. Await further instructions. This is a fire alert. This is a fire alert. Await further instructions.	M0
2	Apollo Evacuation Tone* (550Hz for 0.5s, 825Hz for 0.5s)	In the interest of safety please evacuate the building now. In the interest of safety please evacuate the building now. In the interest of safety please evacuate the building now.	M3	Apollo Alert Tone (1s off, 825Hz for 1s)	All clear. The emergency has been resolved. It is safe to resume normal activities. All clear. The emergency has been resolved. It is safe to resume normal activities.	M2
3	Apollo Evacuation Tone (550Hz for 0.5s, 825Hz for 0.5s)	This is a test of the fire alarm system. Please do not take any action. This is a test of the fire alarm system. Please do not take any action.	M5	Apollo Alert Tone (1s off, 825Hz for 1s)	The fire alarm test is now complete. The fire alarm test is now complete. The fire alarm test is now complete.	M4
4	Fast Sweep (2500Hz-2850Hz at 9Hz)	Spare	M7	Continuous 2850Hz	Spare	M6
5	Dutch Slow Whoop (Sweep 500Hz - 1200Hz for 3.5s, 0.5s off)	Spare	M9	Continuous 825Hz	Spare	M8
6	DIN Tone (Sweep 1200Hz - 500Hz for 1s)	Spare	M11	Continuous 825Hz	Spare	M10
7	Swedish Fire Tone 660Hz, 150ms on, 150ms off)	Spare	M13	Swedish hall clear signal (Continuous 660Hz)	Spare	M12
8	Aus (fast rise sweep 3x (500Hz - 1200Hz for 0.5s), 0.5s off)	Spare	M15	Aus Alert Tone (420Hz, 0.625s, 0.625s off)	Spare	M14
9	NZ (slow rise sweep 500Hz - 1200Hz for 3.7s, 0.25s off)	Spare	M17	NZ Alert Tone (420Hz, 0.625s, 0.625s off)	Spare	M16
10	US Temporal LF (ISO 8201 3x(970Hz, 0.5s on, 0.5s off), 1s off)	Spare	M19	Continuous 970Hz	Spare	M18
11	US Temporal HF (ISO 8201 3x(2850Hz, 0.5s on, 0.5s off), 1s off)	Spare	M21	Continuous 2850Hz	Spare	M20
12	Simulated Bell-Continuous	Spare	M23	Simulated Bell - Intermittent (1s off, 1s on)	Spare	M22
13	Apollo Evacuation Tone (550Hz for 0.5s, 825Hz for 0.5s)	Spare	M25	Apollo Alert Tone (1s off, 825Hz for 1s)	Spare	M24
14	Continuous 970Hz	Spare	M27	Intermittent 970Hz (1s off, 1s on)	Spare	M26
15	Apollo Evacuation Tone (550Hz for 0.5s, 825Hz for 0.5s)	Spare	M29	Apollo Alert Tone (1s off, 825Hz for 1s)	Spare	M28

Table 2 \*EN54 Compliant

### FUNCTION

The Discovery® Open-Area Voice Alarm Devices comprise of a sounder and a sounder beacon. Details of the range are shown in Table 1 overleaf. It is supplied with a backbox which incorporates a short-circuit isolator.

### APPLICATION

The Discovery Open-Area Voice Alarm Devices are used to provide audible and visual warning of a fire condition and are controlled by the fire control panel by means of the Discovery protocol. *This particular feature is only available when being controlled by the full Discovery protocol, with the panel programmed accordingly. Information on available features should be requested from the panel manufacturer.*

### FEATURES

The Discovery Open-Area Voice Alarm Devices offers:

- 6 messages
- 7 volume levels
- Software-defined group addressing with up to 16 group addresses
- Alarm switching by individual device, by group address or of all devices on loop
- Independent control of sounder and beacon
- Isolator status information

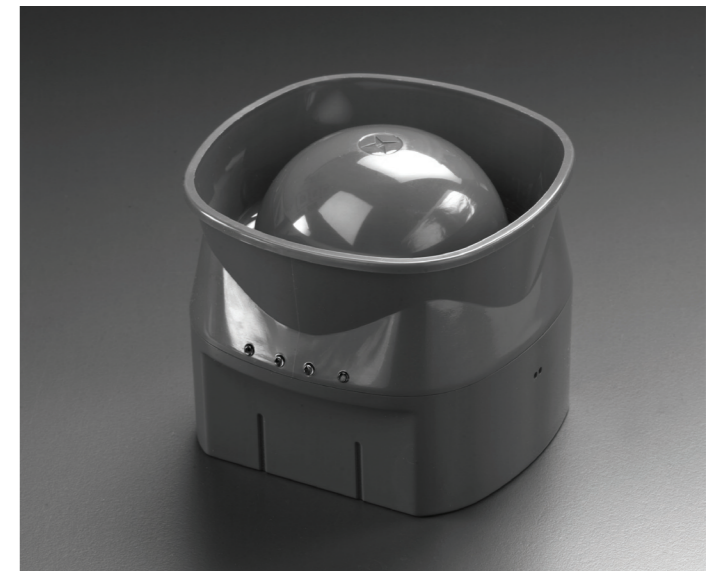

Open-Area Voice Sounder (Red) 58000-010

- Set-up and testing of devices at point of installation
- Optional noise pollution feature; automatically silences after 20 minutes
- Class change bell tone
- Red or white options



Overseas offices:  
America China Germany Ireland

36 Brookside Road, Havant,  
Hampshire, PO9 1JR, UK.  
A HALMA COMPANY

Tel: +44 (0)23 9249 2412  
Fax: +44 (0)23 9249 2754

Email: sales@apollo-fire.co.uk  
Web: www.apollo-fire.co.uk

Part Number	Product Name	Type	Colour
58000-010	Discovery Open-Area Voice Sounder	Indoor (Type A)	Red
58000-020	Discovery Open-Area Voice Sounder	Indoor (Type A)	White
58000-030	Discovery Open-Area Voice Sounder Beacon	Indoor (Type A)	Red
58000-040	Discovery Open-Area Voice Sounder Beacon	Indoor (Type A)	White

**Table 1** Discovery Open-Area Voice Alarm Devices

### ADVANTAGES OF THE OPEN-AREA VOICE ALARM DEVICES

#### The right tone for your installation

The Discovery Open-Area Voice Alarm Devices offer a choice of 2 evacuation tones/messages. One of these tone/messages is selected during commissioning in order to suit local regulations or customs. A fire alarm test message is also available.

Whichever evacuation tone/message is selected there is a secondary tone/message which may be used for alerting or warning of a possible evacuation. A full list of available tones/messages is listed in Table 2 overleaf.

#### The right level of sound

This is set during commissioning to one of 7 levels of sound, the highest level being nominally 97dB(A). For more information on volume levels see Table 3 below.

At 60dB(A) the lowest level falls outside the scope of the standard EN54. It has been included to provide a very local warning for the use of personnel in particular environments, such as nurse stations in hospitals.

Volume Level	dB(A) of Tone
1	60
2	72
3	77
4	82
5	87
6	92
7	97

**Table 3** Volume Levels

#### Flexibility of group addressing

In many installations a fire alarm must be raised by switching more than one sounder to alert or alarm simultaneously. This is achieved by assigning devices to groups. One command will then switch *all* devices in the group.

#### Sounder, beacon or both

The Discovery Open-Area Voice Alarm Devices normally switches both sounder and beacon to provide an alert or evacuation signal. There might be instances where a flash or a sounder would not be permitted.

It is a simple choice as to whether to switch both sounder and beacon together or to switch either as necessary.

#### Location-specific volume setting

Detectors and sounder beacons are installed in many different types of environment.

When configuring the Discovery Open-Area Voice Alarm Devices the adjustment of the volume can be done *at the point of installation*.

The commissioning engineer simply sets the control panel to 'Set-up'\* and then walks from one device to the next to set the required volume, using a magnetic wand, part no 29650-001. When all devices have been set the engineer simply presses a button on the control panel which then registers all the individual volume settings.

\*Panel dependant

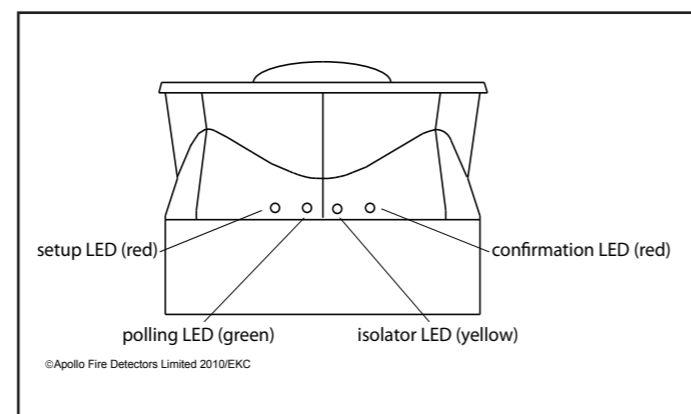

#### LED INDICATION

There are four LEDs on the front of the Discovery Open-Area Voice Alarm Devices.

A red setup LED indicates where to position the magnetic wand for setup and test feature.

A green polling LED flashes when the device is interrogated. The polling LED feature is configured on the control panel.

The yellow LED indicates the isolator status.

A red feedback LED indicates the acknowledgement of the magnetic wand function.

#### DIMENSIONS AND WEIGHT

105mm x 105mm x 90mm (L x W x H) 290g

#### DIMENSIONAL DIAGRAMS (mm)

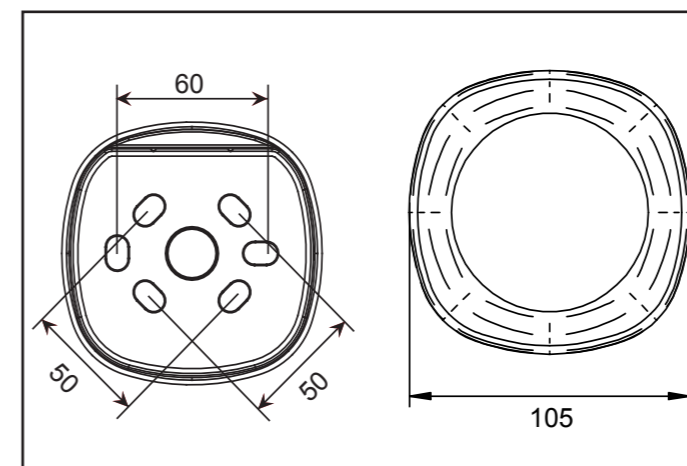

#### PROTOCOL USAGE

The Discovery Open-Area Voice Alarm Devices only operates with the Discovery protocol, for details please see Table 4 below.

Output Bits	
2	Beacon control
1	Sounder control
0	0=Alert, 1=Evacuate
Interrupt	No
Analogue Value	
1	Sounder failure
2	Beacon failure
3	Sounder and beacon failure
4	General fault
17 to 23	Quiescent, volume setting 1 to 7
Input Bits	
2	Beacon status, 1=On
1	Sounder status, 1=On
0	Confirmation of Alert (0), Evacuate (1)
Flag Setting	
XP95 Flag	Yes
Alarm Flag	No

**Table 4** Protocol Usage

#### TECHNICAL DATA

Operating voltage (polarity sensitive)	17–28V DC
Protocol pulses	5–9V
Current consumption at 24V	
switch-on surge, <10s	1.9mA
quiescent	1.4mA
sounder on	9.5mA
beacon on	8.9mA
sounder and beacon on	13.4mA
Maximum sound output at 90°	
tone	97dB(A)
voice	92dB(A)
Sound pressure level data is published in PIN sheet PP2203 available from Apollo on request.	
Operating temperature	–20°C to +60°C
Humidity (no condensation)	0–95%
IP rating	21C