

Functional Test Data

Protocol bit use:

Output Bit	Function	Input Bit	Function
2	not used	2	not used
1	not used	1	not used
0	operates relay 1 = set 0 = reset	0	not used

For further information on protocol bit usage, refer to the DIN-Rail Mounted Output Unit PIN sheet, PP2046.

Troubleshooting

Before investigating individual units for faults, it is important to check that the system wiring is fault free. Earth faults on data loops or interface zone wiring may cause communication errors.

Many fault conditions are the result of simple wiring errors. Check all connections to the unit and make sure that the correct value resistors are fitted where necessary.

Fault Finding

Problem	Possible Cause
No response or missing	Incorrect address setting Incorrect loop wiring
Relay fails to operate	Incorrect wiring Control panel has incorrect cause and effect programming
Relay energised continuously	Control panel has incorrect cause and effect programming Incorrect address setting



Marine DIN-Rail Mounted Output Unit Installation Guide

General

The Marine DIN-Rail Mounted Output Unit, part no. 55000-771MAR, is designed to be mounted inside an enclosure, clipped onto a standard 35mm DIN rail (DIN 46277) or mounted directly to the enclosure using two 4mm screws.

The installation must conform to BS5839 (or applicable local codes) and be carried out such that the unit is not subjected to:

- exposure to risk of mechanical damage
- unauthorised modification or interference
- exposure to moisture, dust and foreign bodies
- exposure to temperatures exceeding the maximum ambient

The address of the unit is set on segments 1–7 of the DIL switch. Segment 8 is used to disable the indicating LED if it is not required or the extra loop current to illuminate it is not available.

The unit is loop powered and controlled by the control panel using the output bits in the communication protocol.

Installation

1. Run the cables from the loop and the relay connections as required into the unit. Ensure that earth continuity is maintained.
2. Set the unit address on segments 1–7 of the DIL switch in accordance with the address table.

If the LED is to be disabled, set segment 8 of the DIL switch to OFF.
3. Remove the backing strip from the lower portion of the label.
4. Fix the lower portion of the label firmly to the unit, ensuring the DIL switch access hole is covered.
5. *Either* clip the unit to the standard 35mm DIN-Rail (DIN 46277)
Or fully extend the latches from the base of the unit and secure the unit to the enclosure using two 4mm screws with a spacing of 90mm.

Wiring Details

All wiring terminals accept solid or stranded cables up to 2.5mm².

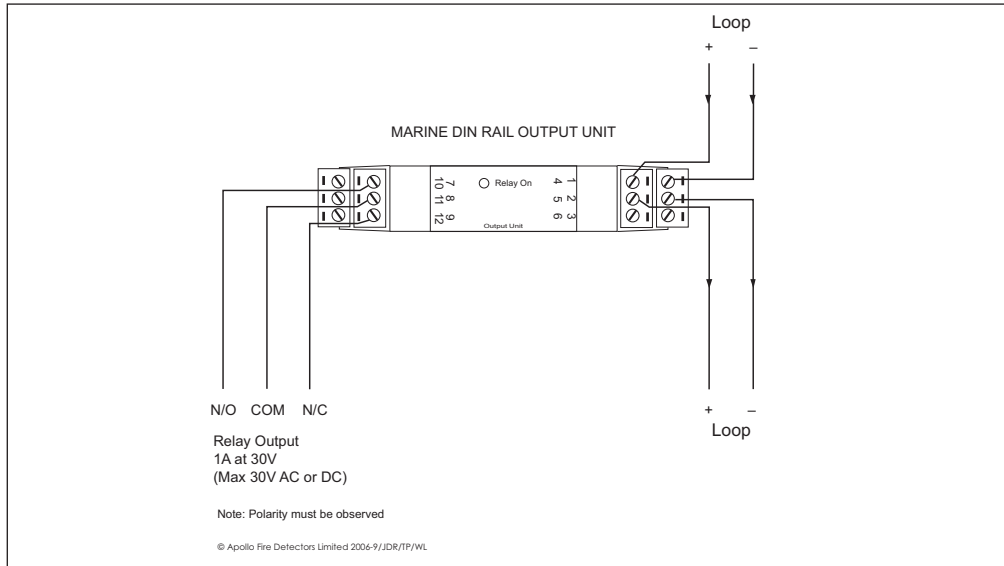

Maximum Loop Current Consumption at 28V

	LED enabled	LED disabled
switch-on surge, max 160ms	3mA	3mA
quiescent	1mA	1mA
relay energised	3.3mA	1mA

Address Setting

The address of the Output Unit is set using seven segments of the eight-segment DIL switch. The eighth segment selects LED enabled (0) or disabled (1). Segments 1-7 of the switch are set to 0 or 1, using a small screwdriver or similar tool.

A complete list of address settings is shown in the following table.

addr	DIL switch setting 1234567	addr	DIL switch setting 1234567	addr	DIL switch setting 1234567	addr	DIL switch setting 1234567	addr	DIL switch setting 1234567
1	1000000	11	1101000	21	1010100	31	1111100	41	1001010
2	0100000	12	0011000	22	0110100	32	0000010	42	0101010
3	1100000	13	1011000	23	1110100	33	1000010	43	1101010
4	0010000	14	0111000	24	0001100	34	0100010	44	0011010
5	1010000	15	1111000	25	1001100	35	1100010	45	1011010
6	0110000	16	0000100	26	0101100	36	0010010	46	0111010
7	1110000	17	1000100	27	1101100	37	1010010	47	1111010
8	0001000	18	0100100	28	0011100	38	0110010	48	0000110
9	1001000	19	1100100	29	1011100	39	1110010	49	1000110
10	0101000	20	0010100	30	0111100	40	0001010	50	0100110
51	1100110	61	1011110	71	1110001	81	1000101	91	1101101
52	0010110	62	0111110	72	0001001	82	0100101	92	0011101
53	1010110	63	1111110	73	1001001	83	1100101	93	1011101
54	0110110	64	0000001	74	0101001	84	0010101	94	0111101
55	1110110	65	1000001	75	1101001	85	1010101	95	1111101
56	0001110	66	0100001	76	0011001	86	0110101	96	0000011
57	1001110	67	1100001	77	1011001	87	1110101	97	1000011
58	0101110	68	0010001	78	0111001	88	0001101	98	0100011
59	1101110	69	1010001	79	1111001	89	1001101	99	1100011
60	0011110	70	0110001	80	0000101	90	0101101	100	0010011
101	1010011	106	0101011	111	1111011	116	0010111	121	1001111
102	0110011	107	1101011	112	0000111	117	1010111	122	0101111
103	1110011	108	0011011	113	1000111	118	0110111	123	1101111
104	0001011	109	1011011	114	0100111	119	1110111	124	0011111
105	1001011	110	0111011	115	1100111	120	0001111	125	1011111
								126	0111111

Commissioning

It is important that the Marine DIN-Rail Mounted Output Unit be fully tested after installation. An XP95 Test Set, part no. 55000-870, may be used to carry out functional testing of individual units. The test set can also perform data integrity tests of an entire system.

LED Indicator

⊙ Relay on Illuminated red when relay is energized